

SW EW INSET GIRT CONDITIONS

- CB0015 - SW OR EW HOT ROLL INSET GIRT DETAIL
 - CB1001 - INSET GIRT BOLT PLACEMENT DETAIL
 - CB1010 - INSET GIRT DETAIL
 - CB2000 - INSET GIRT TO ENDWALL RAFTER DETAIL
 - CB2010 - GIRT TO SINGLE CEE RAFTER
 - CB2020 - GIRT TO DOUBLE CEE RAFTER
-

CB0015 - SW OR EW HOT ROLL INSET GIRT DETAIL

[Download the DWG file by clicking here.](#)

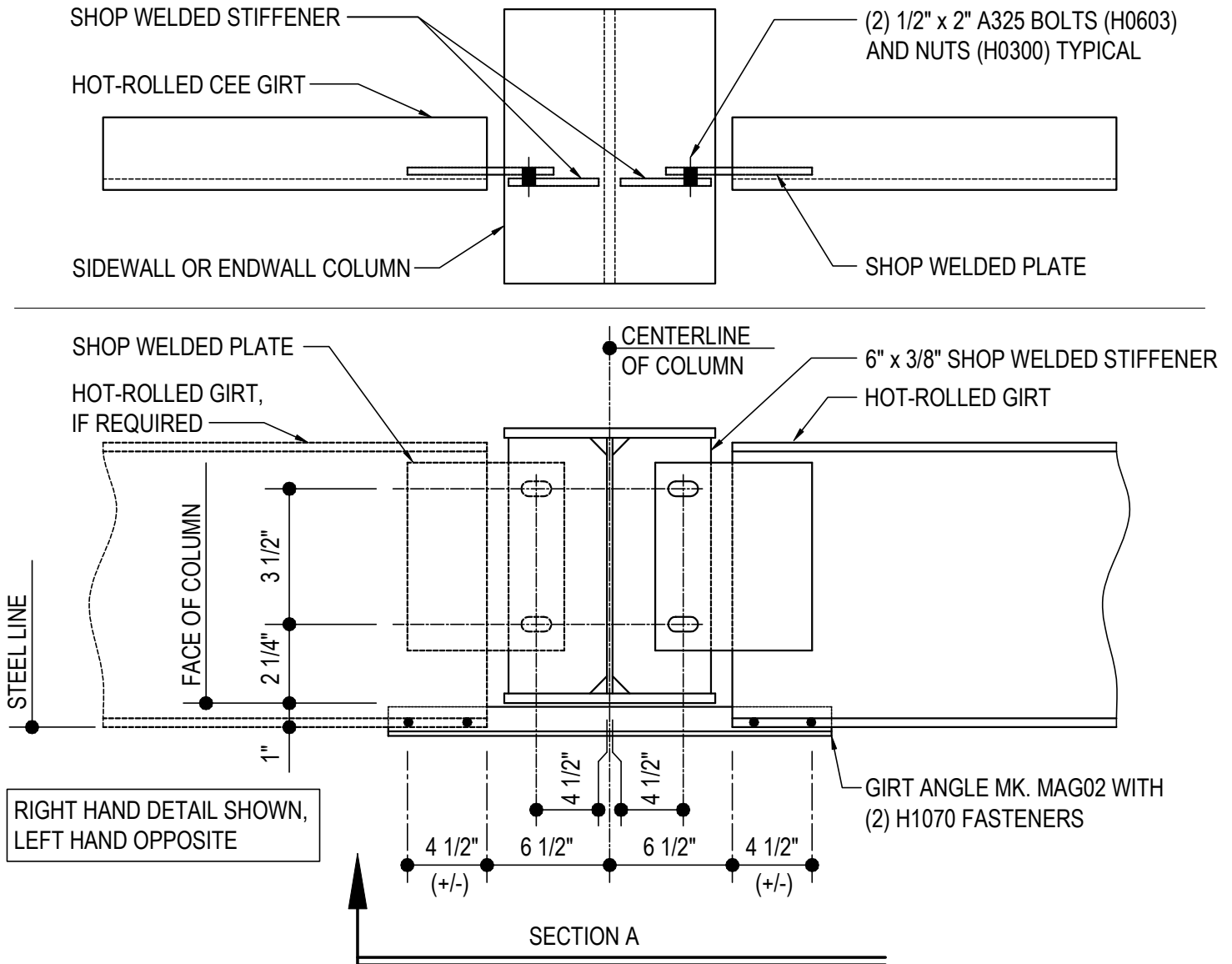

SW OR EW HOT ROLL GIRT DETAIL

INSET GIRTS AT INTERIOR BAY COLUMNS

NOTE: USE (4) 1/2" x 2" A325 BOLTS (MK. H0603) & NUTS (MK. H0300)

REFERENCE ERECTOR NOTE FOR TYPICAL WASHER REQUIREMENTS

CB0015

Detailer Notes:

- 1) SHOP WELDED PLATE AT HOT-ROLLED CEE GIRT = GCP06
- 2) 8" HOT-ROLLED GIRTS MAY NEED TO BE COPED DUE TO POTENTIAL INTERFERENCE BETWEEN THE INSIDE FLANGE AND THE GCP06 CLIP.

CB1001 - INSET GIRT BOLT PLACEMENT DETAIL

[Download the DWG file by clicking here.](#)

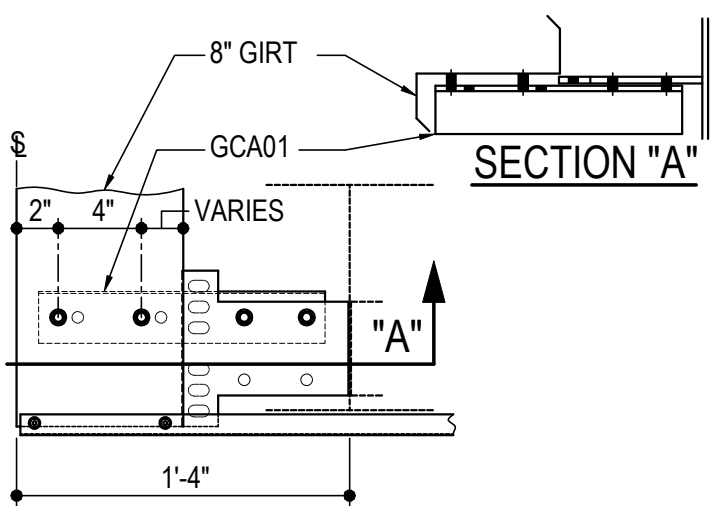

8" OR 12" GIRT AT CORNER

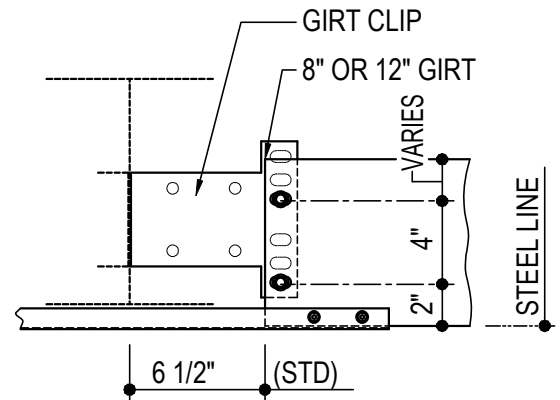

8" OR 12" GIRT AT SW OR EW

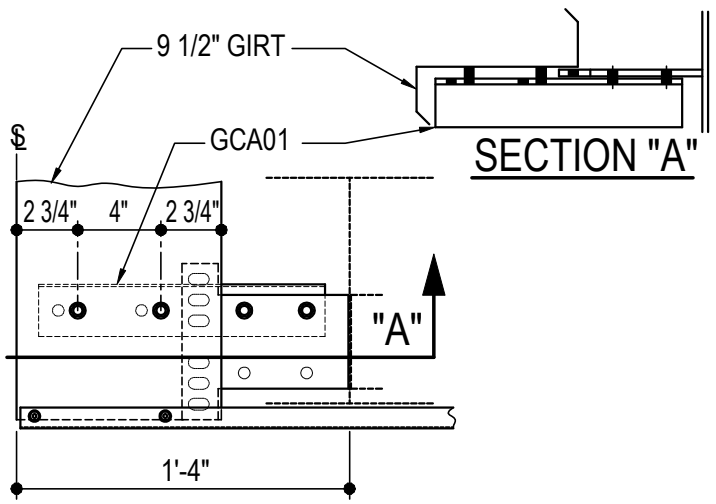

9 1/2" GIRT AT CORNER

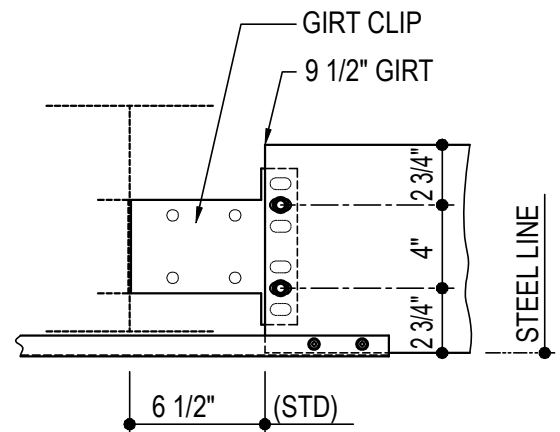

9 1/2" GIRT AT SW OR EW

INSET GIRT BOLT PLACEMENT DETAIL

REFERENCE WASHER DETAIL FOR TYPICAL WASHER REQUIREMENTS
 GIRT CLIPS ARE FACTORY PUNCHED TO BE USED WITH MULTIPLE GIRT DEPTHS.
 REFER TO THE DETAILS ABOVE TO DETERMINE WHICH HOLES ARE UTILIZED.

CB1001

Detailer Notes:

- 1) N/A

(CB1010 - INSET GIRT DETAIL)

[Download the DWG file by clicking here.](#)

ERECTOR NOTE

GIRT CLIPS ARE FACTORY PUNCHED TO BE USED WITH MULTIPLE GIRT DEPTHS.
REFER TO THE STANDARD BOLT PLACEMENT DETAIL(S) FOR PROPER BOLT PLACEMENT.

RIGHT HAND DETAIL SHOWN, LEFT HAND OPPOSITE

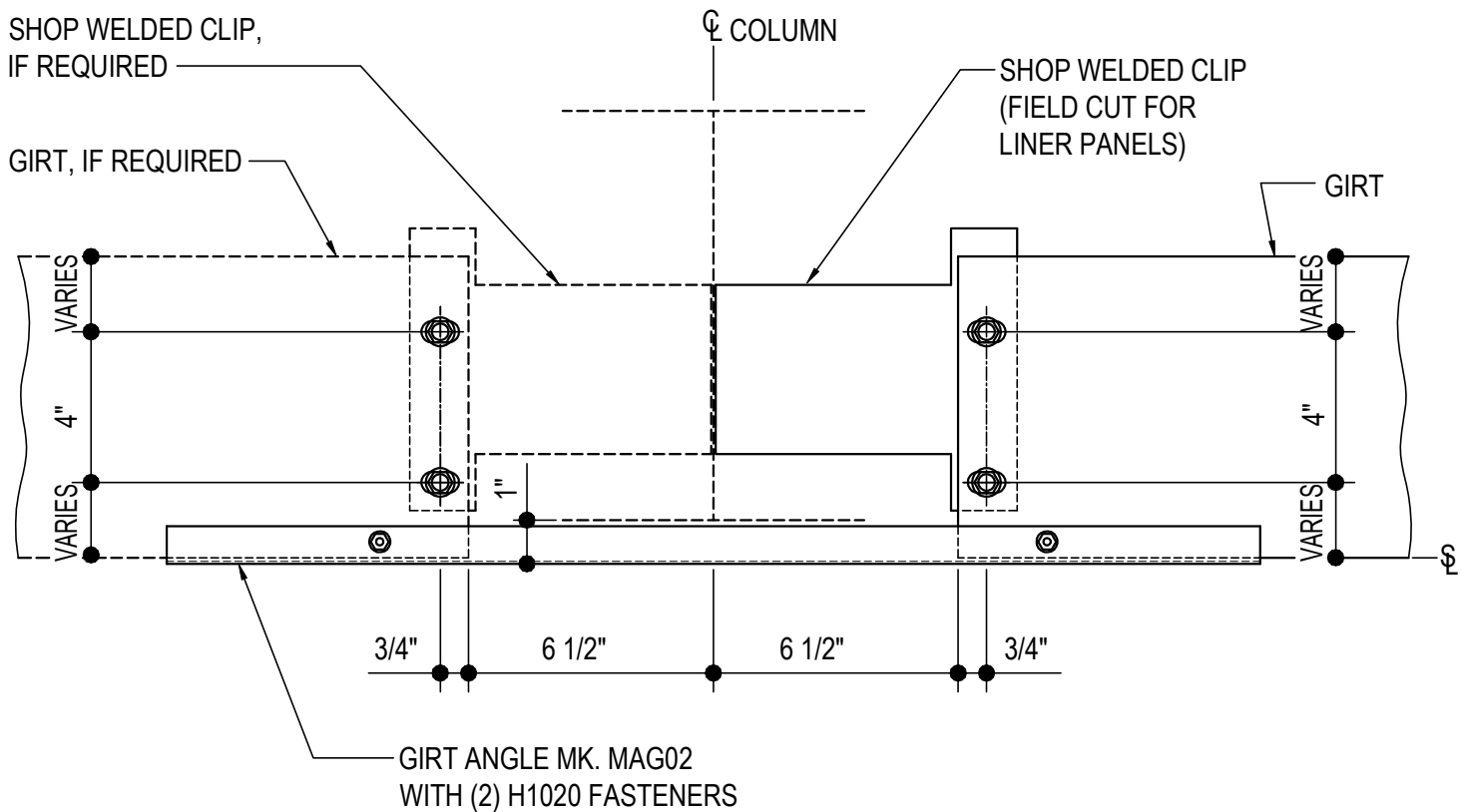

INSET GIRT DETAIL

INSET GIRTS AT INTERIOR BAY COLUMNS

NOTE: USE (4) 1/2" x 1 1/4" A307 BOLTS H0500/NUTS H0400

REFERENCE STANDARD WASHER DETAIL FOR TYPICAL WASHER REQUIREMENTS

CB1010

Detailer Notes:

- 1) WELDED INSET GIRT CLIP TO COLUMN = GF102

CB2000 - INSET GIRT TO ENDWALL RAFTER DETAIL

[Download the DWG file by clicking here.](#)

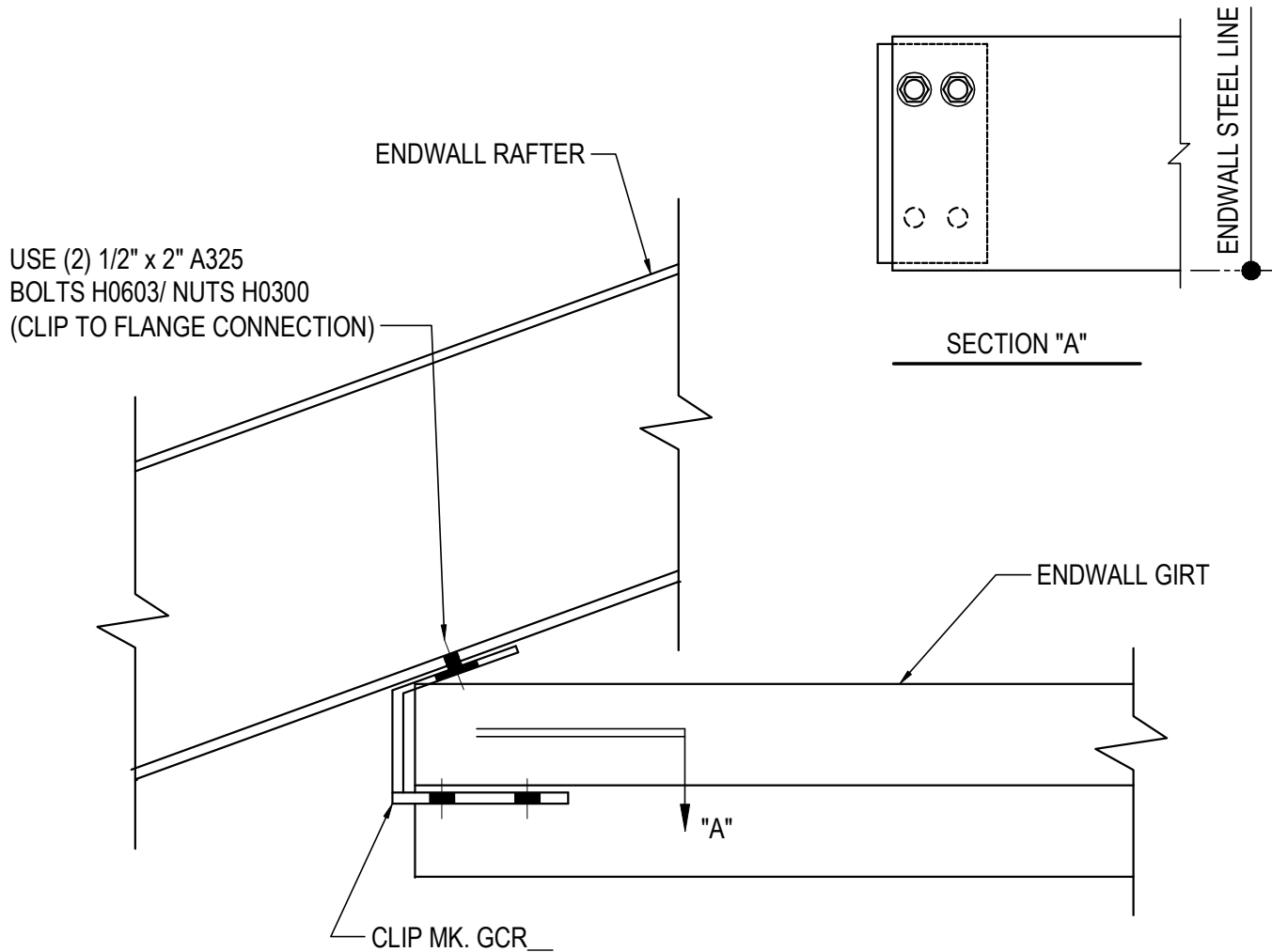

GIRT TO ENDWALL RAFTER

INSET GIRT AT EW RAFTER

(2) 1/2" x 1 1/4" A307 BOLTS H0500/NUTS H0400

REFERENCE ERECTOR NOTE FOR TYPICAL WASHER REQUIREMENTS

CB2000

Detailer Notes:

1) N/A

CB2010 - GIRT TO SINGLE CEE RAFTER

[Download the DWG file by clicking here.](#)

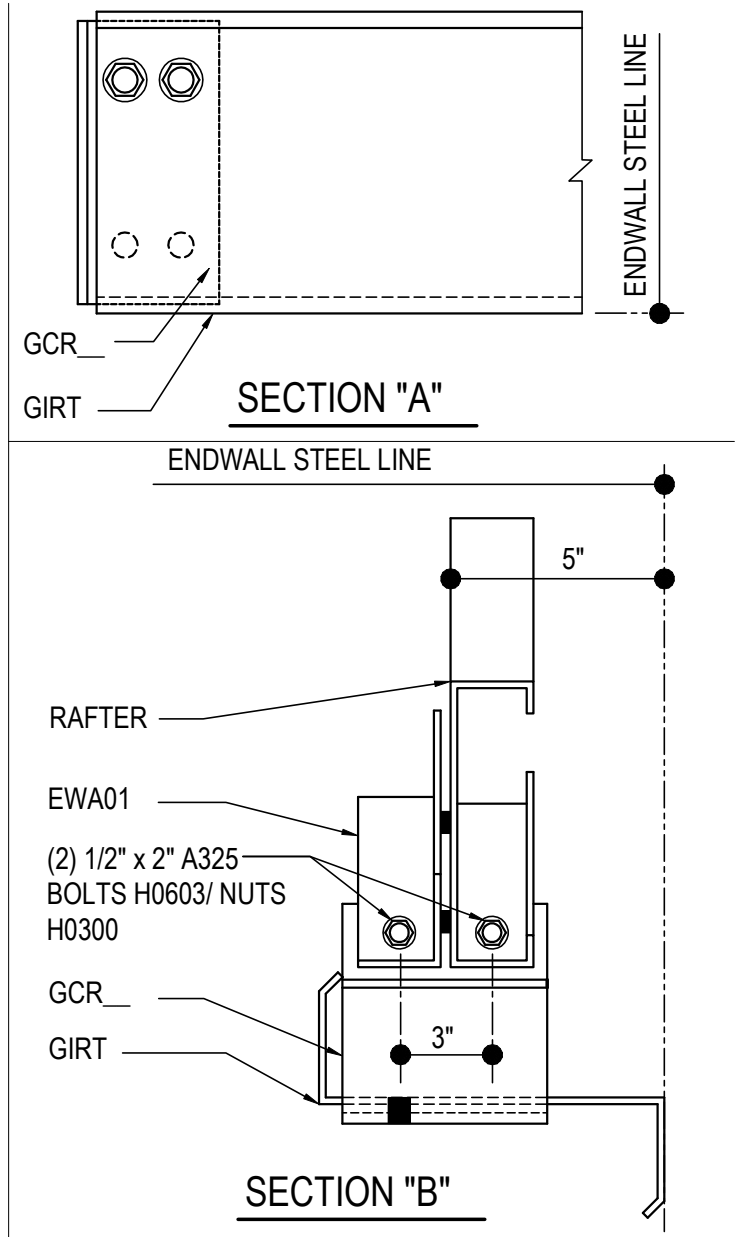
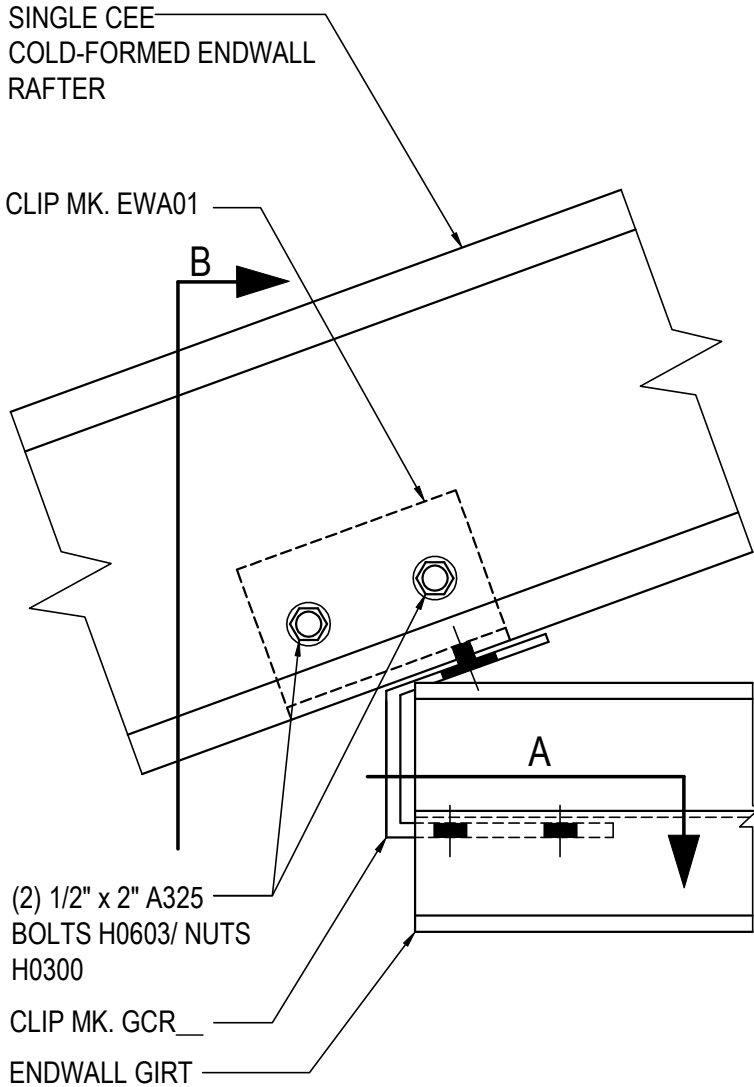

GIRT TO SINGLE CEE RAFTER

INSET ZEE GIRT AT SINGLE CEE COLD-FORMED ENDWALL RAFTER
(2) 1/2" x 1 1/4" A307 BOLTS H0500/NUTS H0400
REFERENCE ERECTOR NOTE FOR TYPICAL WASHER REQUIREMENTS

CB2010

Detailer Notes:

- 1) N/A

CB2020 - GIRT TO DOUBLE CEE RAFTER

[Download the DWG file by clicking here.](#)

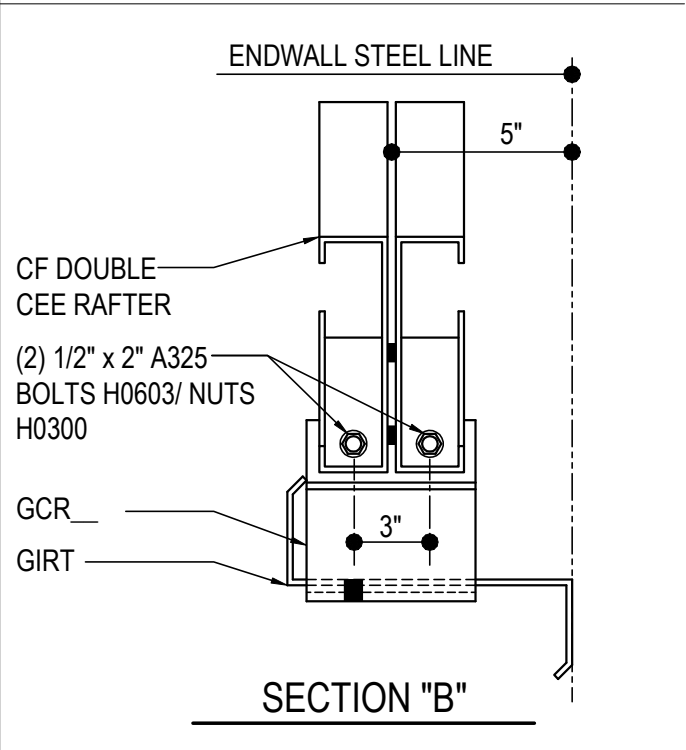
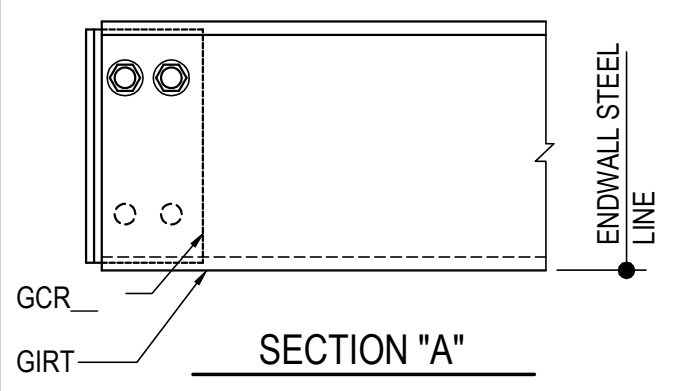
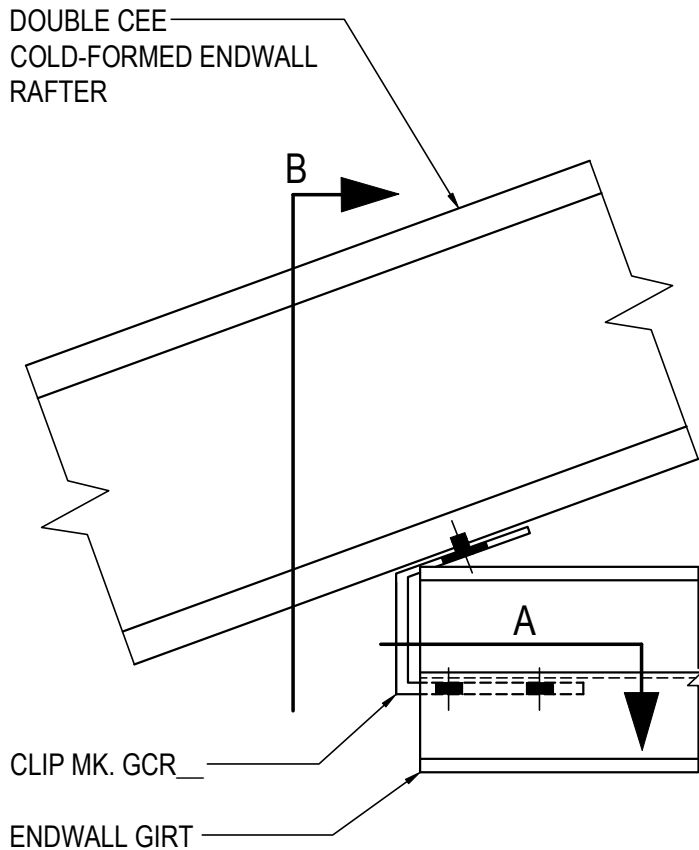

GIRT TO DOUBLE CEE RAFTER

INSET ZEE GIRT AT DOUBLE CEE COLD-FORMED ENDWALL RAFTER
 (2) 1/2" x 1 1/4" A307 BOLTS H0500/NUTS H0400
 REFERENCE ERECTOR NOTE FOR TYPICAL WASHER REQUIREMENTS

CB2020

Detailer Notes:

- 1) N/A